

壁板系统

Wall Panel System

一、适用范围 Scope of Use

各类船舶及海洋工程建筑物上具有耐火分隔要求的舱室和生活模块。

The cabins & living modules with fireproof division requirement of structures on various ships and sea projects.

二、壁板图例 Figure of Wall Panel System

雌雄壁板 Wall Panel (B25A)

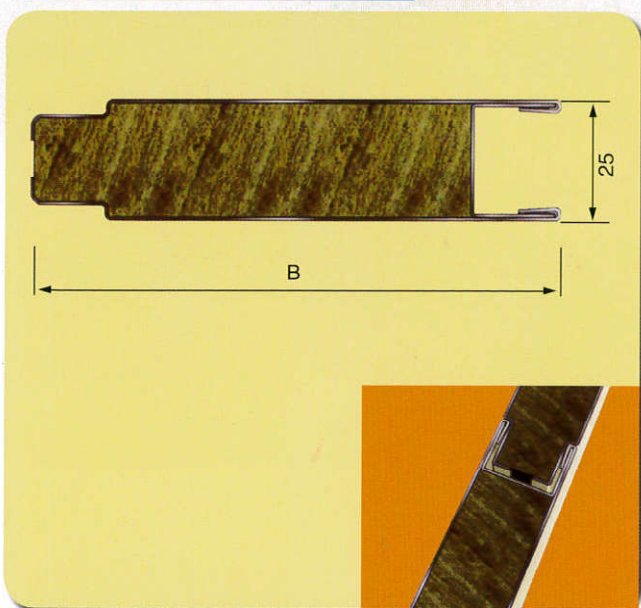

面材 Surface material	0.6mm贴塑钢板 0.6mm PVC laminated steel sheet
芯材 Core material	150kg/m ² 岩棉 150kg/m ² Rockwool
防火等级 Fire class	B-0 / B-15
隔音量 Sound reduction	42dB
传热系数 Thermal conductivity	0.50m ² °C/W
最大长度 Max length	3000mm
板重 Panel weight	14.3kg/m ²

雌雄壁板 Wall Panel (B50A)

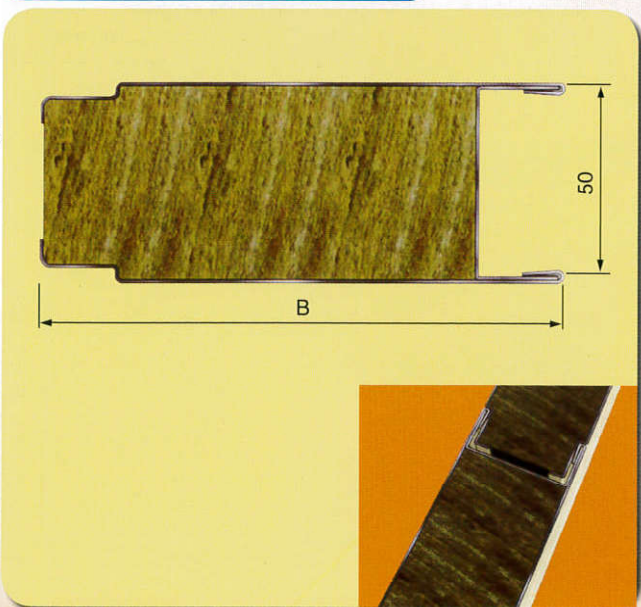

面材 Surface material	0.6mm贴塑钢板 0.6mm PVC laminated steel sheet
芯材 Core material	150kg/m ³ 岩棉 150kg/m ³ Rockwool
防火等级 Fire class	B-0 / B-15
隔音量 Sound reduction	43dB
传热系数 Thermal conductivity	1.04m ² °C/W
最大长度 Max length	3000mm
板重 Panel weight	18.2kg/m ²



壁板系统

Wall Panel System

潮湿壁板 Wet Wall Panel (B25A)

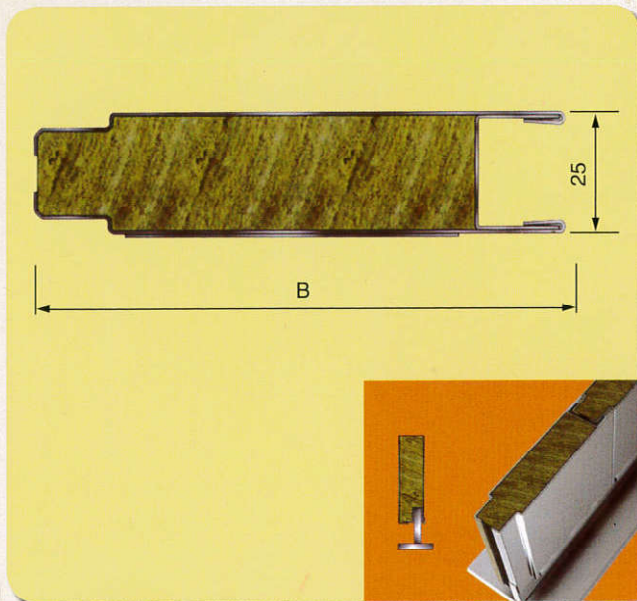

面材 Surface material	0.6mm贴塑钢板 0.6mm PVC laminated steel sheet
芯材 Core material	150kg/m ² 岩棉 150kg/m ² Rockwool
防火等级 Fire class	B-0 / B-15
隔音量 Sound reduction	42dB
传热系数 Thermal conductivity	0.50m ² °C/W
最大长度 Max length	3000mm
板重 Panel weight	14.3kg/m ²

潮湿壁板 Wet Wall Panel (B50A)

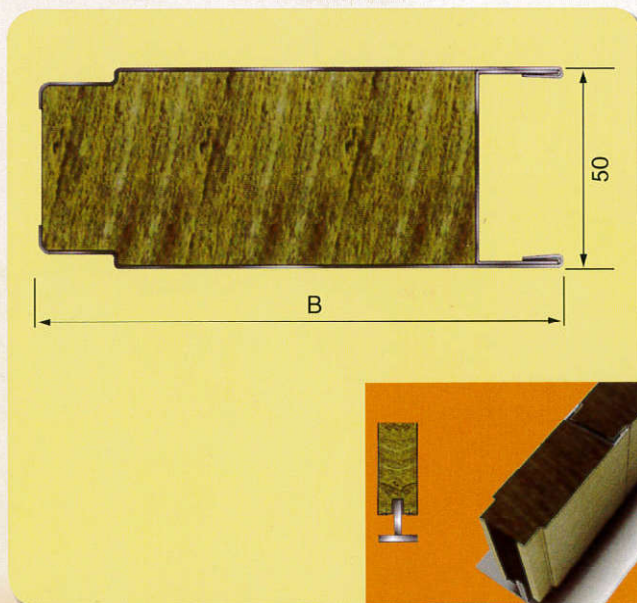

面材 Surface material	0.6mm贴塑钢板 0.6mm PVC laminated steel sheet
芯材 Core material	150kg/m ² 岩棉 150kg/m ² Rockwool
防火等级 Fire class	B-0 / B-15
隔音量 Sound reduction	43dB
传热系数 Thermal conductivity	1.04m ² °C/W
最大长度 Max length	3000mm
板重 Panel weight	18.2kg/m ²

壁板系统

Wall Panel System

LC转角板 LC corner panel (B25A)

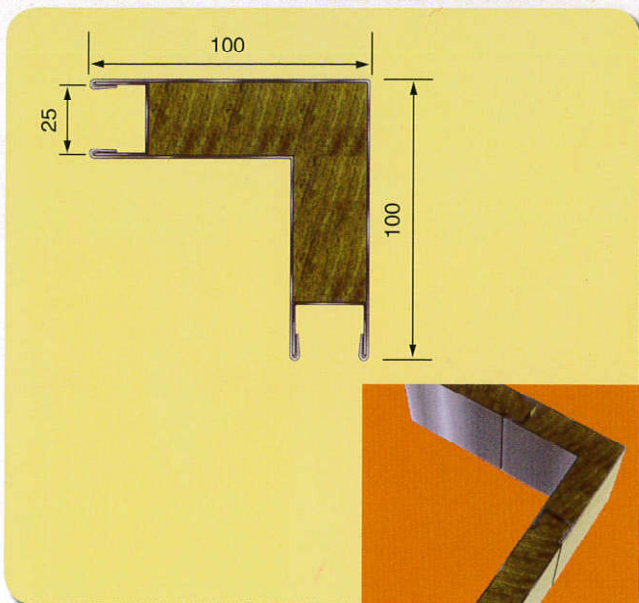

面材 Surface material	0.6mm贴塑钢板 0.6mm PVC laminated steel sheet
芯材 Core material	150kg/m ² 岩棉 150kg/m ² Rockwool
防火等级 Fire class	B-0 / B-15
隔音量 Sound reduction	41dB
传热系数 Thermal conductivity	0.50m ² °C/W
最大长度 Max length	3000mm
板重 Panel weight	14.3kg/m ²

LA转角板 LA corner panel (B50A)

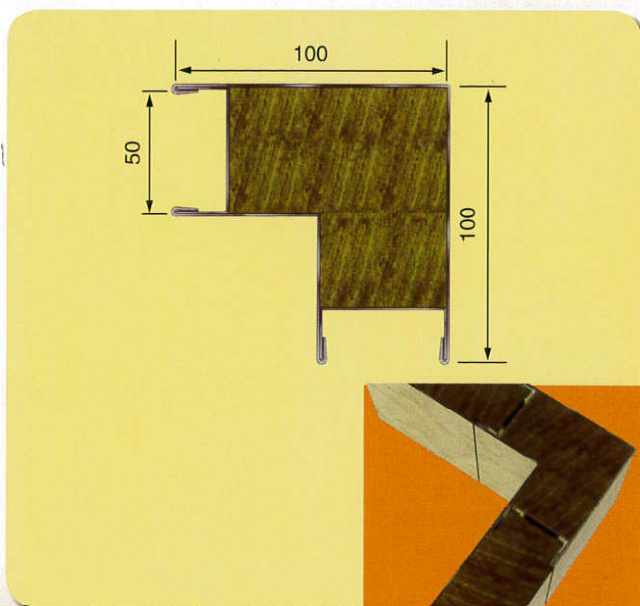

面材 Surface material	0.6mm贴塑钢板 0.6mm PVC laminated steel sheet
芯材 Core material	150kg/m ² 岩棉 150kg/m ² Rockwool
防火等级 Fire class	B-0 / B-15
隔音量 Sound reduction	42dB
传热系数 Thermal conductivity	1.04m ² °C/W
最大长度 Max length	3000mm
板重 Panel weight	18.2kg/m ²



壁板系统

Wall Panel System

LB转角板 LB Corner Panel (B25A)

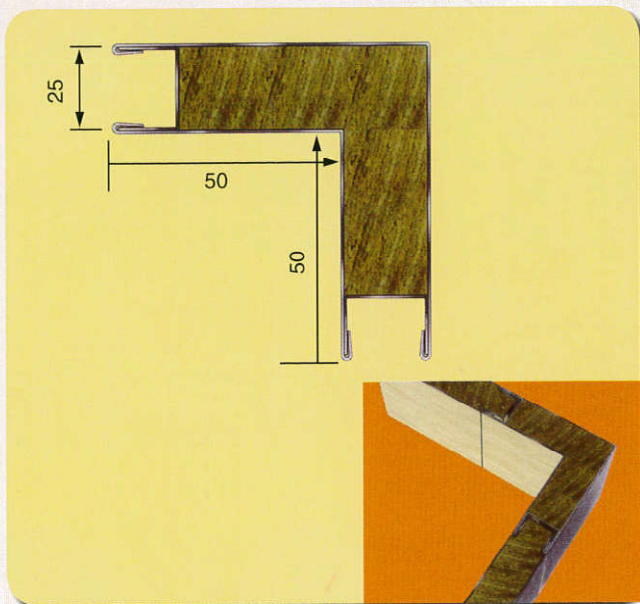

面材 Surface material	0.6mm贴塑钢板 0.6mm PVC laminated steel sheet
芯材 Core material	150kg/m ³ 岩棉 150kg/m ³ Rockwool
防火等级 Fire class	B-0 / B-15
隔音量 Sound reduction	41dB
传热系数 Thermal conductivity	0.50m ² °C/W
最大长度 Max length	3000mm
板重 Panel weight	14.3kg/m ²

LE转角板 LE Corner Panel (B50A/B25A)

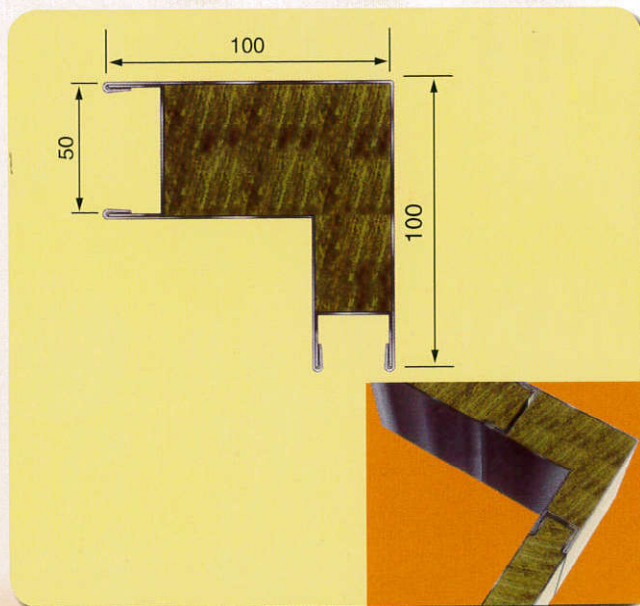

面材 Surface material	0.6mm贴塑钢板 0.6mm PVC laminated steel sheet
芯材 Core material	150kg/m ³ 岩棉 150kg/m ³ Rockwool
防火等级 Fire class	B-0 / B-15
隔音量 Sound reduction	42dB
传热系数 Thermal conductivity	0.50m ² °C/W
最大长度 Max length	3000mm
板重 Panel weight	16.3kg/m ²

壁板系统

Wall Panel System

TA转角板 TA Corner Panel (B50A)

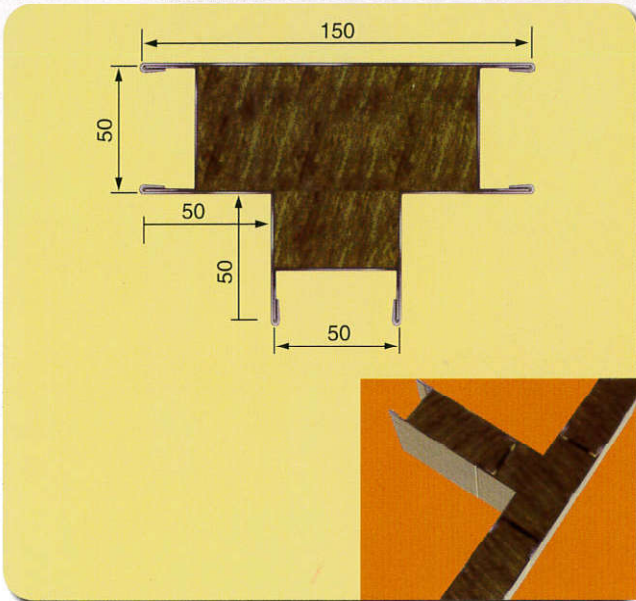

面材 Surface material	0.6mm贴塑钢板 0.6mm PVC laminated steel sheet
芯材 Core material	150kg/m ³ 岩棉 150kg/m ² Rockwool
防火等级 Fire class	B-0 / B-15
隔音量 Sound reduction	42dB
传热系数 Thermal conductivity	1.04m ² °C/W
最大长度 Max length	3000mm
板重 Panel weight	18.2kg/m ²

TB转角板 TB Corner Panel (B50A/B25A)

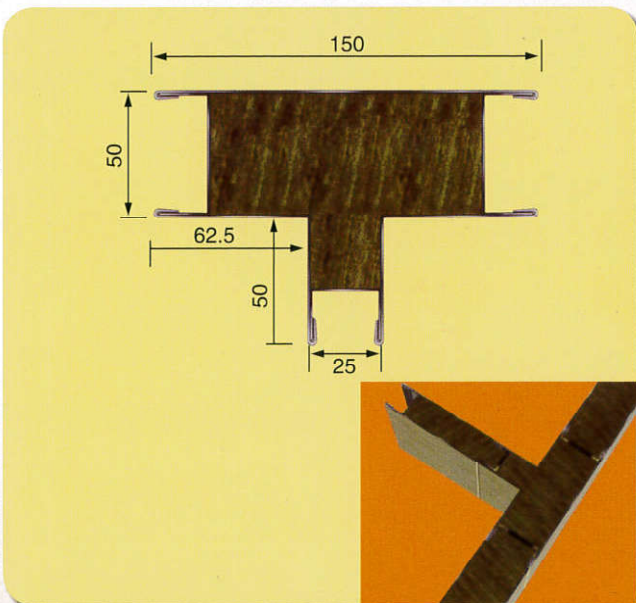

面材 Surface material	0.6mm贴塑钢板 0.6mm PVC laminated steel sheet
芯材 Core material	150kg/m ³ 岩棉 150kg/m ³ Rockwool
防火等级 Fire class	B-0 / B-15
隔音量 Sound reduction	42dB
传热系数 Thermal conductivity	0.50m ² °C/W
最大长度 Max length	3000mm
板重 Panel weight	16.3kg/m ²



壁板系统

Wall Panel System

C型单面板 Type-C Single Side Panel (B25C/B30C)

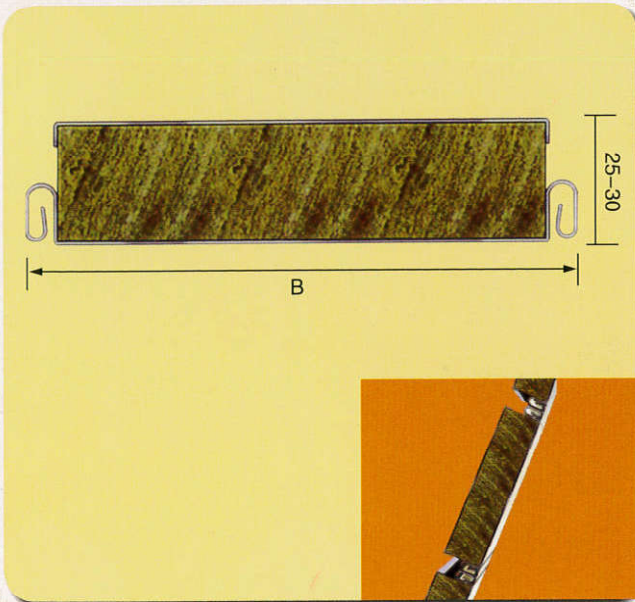

面材 Surface material	0.6mm贴塑钢板 0.6mm PVC laminated steel sheet
芯材 Core material	150kg/m ³ 岩棉 150kg/m ³ Rockwool
防火等级 Fire class	B-0 / B-15
隔音量 Sound reduction	42dB
传热系数 Thermal conductivity	0.55m ² °C/W
最大长度 Max length	3000mm
板重 Panel weight	13.9kg/m ²

C型双面板 Type-C Double Sides Panel (B50C)

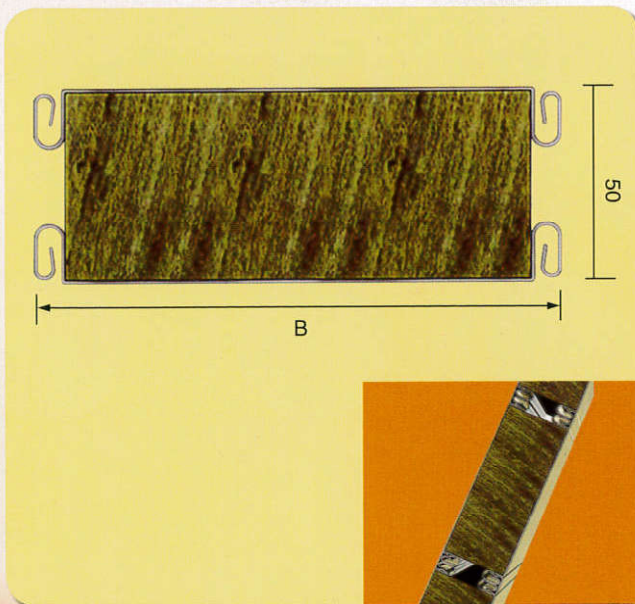

面材 Surface material	0.6mm贴塑钢板 0.6mm PVC laminated steel sheet
芯材 Core material	150kg/m ³ 岩棉 150kg/m ³ Rockwool
防火等级 Fire class	B-0 / B-15
隔音量 Sound reduction	43dB
传热系数 Thermal conductivity	1.04m ² °C/W
最大长度 Max length	3000mm
板重 Panel weight	17.9kg/m ²

壁板系统

Wall Panel System

型L转角版板 Type-C Panel (B50C)

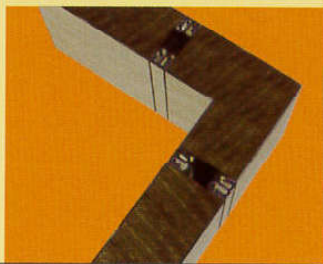
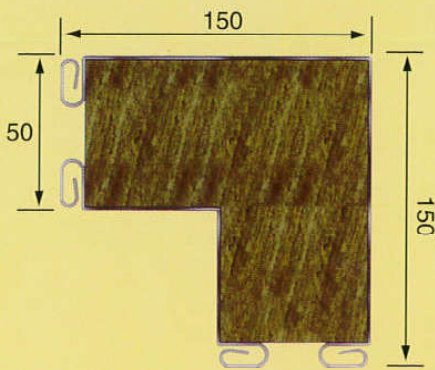

面材 Surface material	0.6mm贴塑钢板 0.6mm PVC laminated steel sheet
芯材 Core material	150kg/m ³ 岩棉 150kg/m ³ Rockwool
防火等级 Fire class	B-0 / B-15
隔音量 Sound reduction	42dB
传热系数 Thermal conductivity	1.04m ² °C/W
最大长度 Max length	3000mm
板重 Panel weight	17.9kg/m ²

型L内转角 L Incorner of Type-C Panel (B25C)

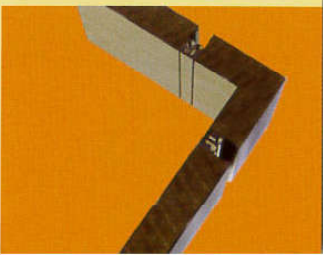
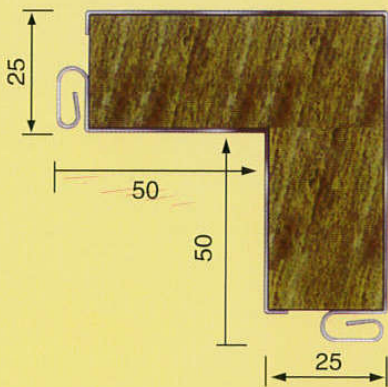

面材 Surface material	0.6mm贴塑钢板 0.6mm PVC laminated steel sheet
芯材 Core material	150kg/m ³ 岩棉 150kg/m ³ Rockwool
防火等级 Fire class	B-0
隔音量 Sound reduction	42dB
传热系数 Thermal conductivity	0.55m ² °C/W
最大长度 Max length	3000mm
板重 Panel weight	13.9kg/m ²



壁板系统

Wall Panel System

C型TA转角板 TA Corner of Type-C Panel (B50C)

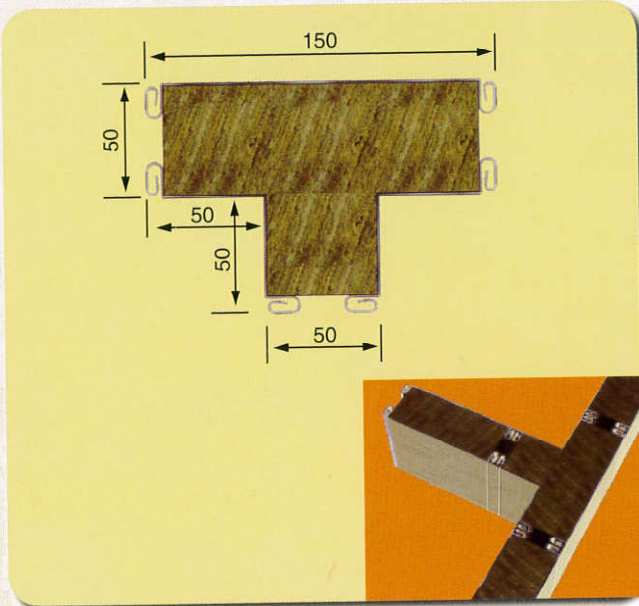

面材 Surface material	0.6mm贴塑钢板 0.6mm PVC laminated steel sheet
芯材 Core material	150kg/m ³ 岩棉 150kg/m ³ Rockwool
防火等级 Fire class	B-0 / B-15
隔音量 Sound reduction	42dB
传热系数 Thermal conductivity	1.04m ² °C/W
最大长度 Max length	3000mm
板重 Panel weight	17.9kg/m ²

C型TB转角板 TB Corner of Type-C Panel (B50C / B25C)

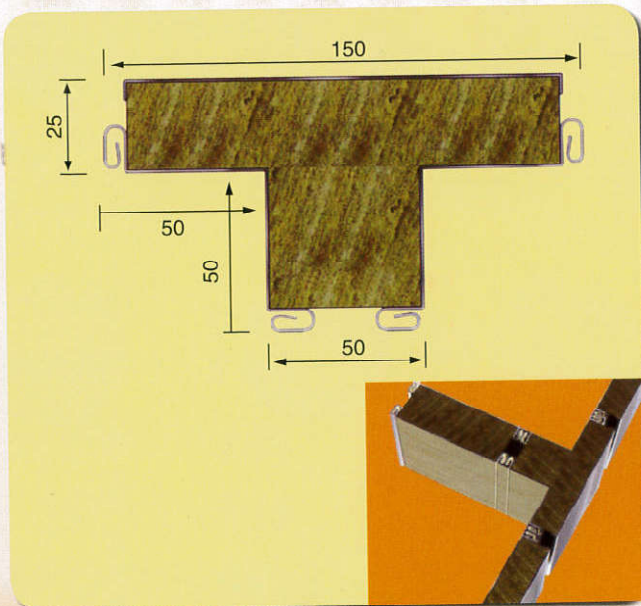

面材 Surface material	0.6mm贴塑钢板 0.6mm PVC laminated steel sheet
芯材 Core material	150kg/m ³ 岩棉 150kg/m ³ Rockwool
防火等级 Fire class	B-0 / B-15
隔音量 Sound reduction	42dB
传热系数 Thermal conductivity	0.55m ² °C/W
最大长度 Max length	3000mm
板重 Panel weight	15.9kg/m ²

壁板系统

Wall Panel System

高隔音壁板 High Sound Reduction Panel (B70G)

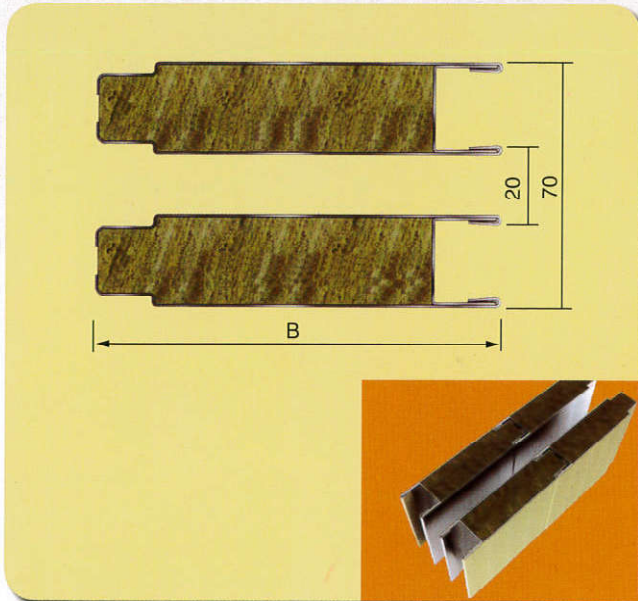

面材 Surface material	0.6mm贴塑钢板 0.6mm PVC laminated steel sheet
芯材 Core material	180~200kg/m ³ 岩棉 180~200kg/m ³ Rockwool
防火等级 Fire class	B-0 / B-15
隔音量 Sound reduction	46dB
传热系数 Thermal conductivity	1.84m ² °C/W
最大长度 Max length	3000mm
板重 Panel weight	28.6kg/m ²

高隔音壁板 High Sound Reduction Panel (B50G)

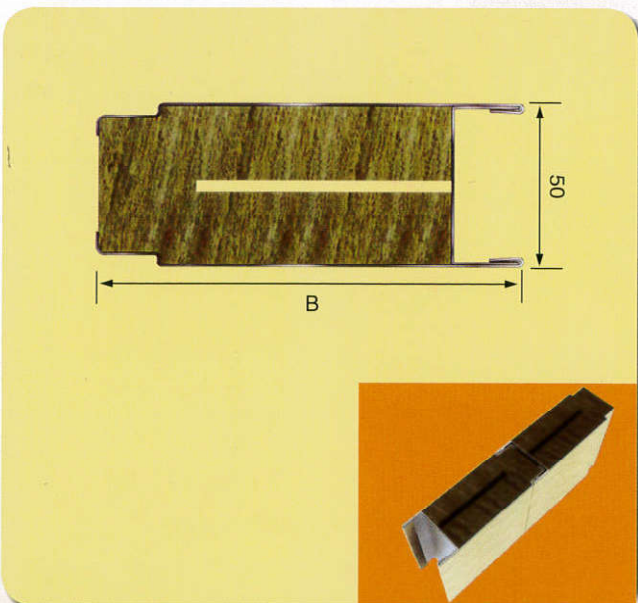

面材 Surface material	0.6mm贴塑钢板 0.6mm PVC laminated steel sheet
芯材 Core material	150kg/m ³ 岩棉 150kg/m ³ Rockwool
防火等级 Fire class	B-0 / B-15
隔音量 Sound reduction	45dB
传热系数 Thermal conductivity	1.04m ² °C/W
最大长度 Max length	3000mm
板重 Panel weight	29.0kg/m ²



壁板系统

Wall Panel System

吸音壁板 Sound Absorbing Panel (B25X)

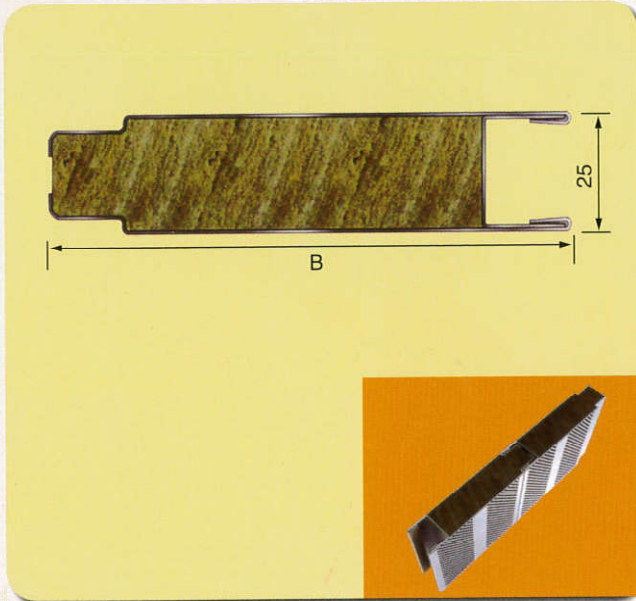

面材 Surface material	0.6mm贴塑钢板 0.6mm PVC laminated steel sheet
芯材 Core material	150kg/m ³ 岩棉 150kg/m ³ Rockwool
防火等级 Fire class	B-0 / B-15
隔音量 Sound reduction	0.8dB
传热系数 Thermal conductivity	0.58m ² °C/W
最大长度 Max length	3000mm
板重 Panel weight	12.7kg/m ²

吸音壁板 Sound Absorbing Panel (B50X)

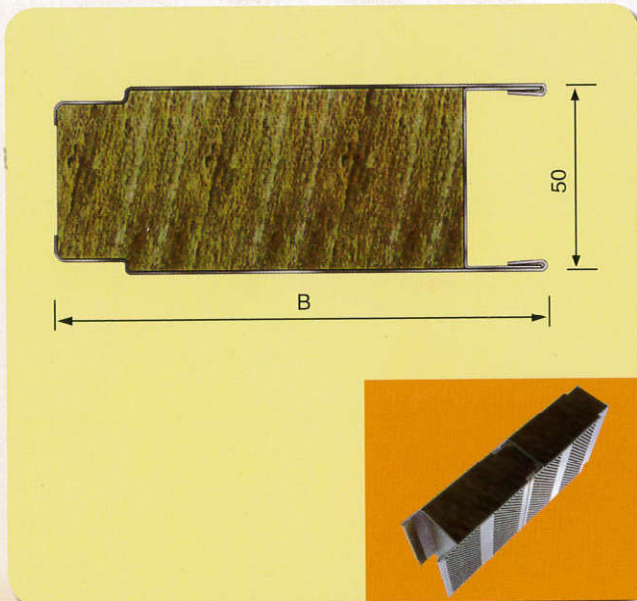

面材 Surface material	0.6mm贴塑钢板 0.6mm PVC laminated steel sheet
芯材 Core material	150kg/m ³ 岩棉 150kg/m ³ Rockwool
防火等级 Fire class	B-0 / B-15
隔音量 Sound reduction	0.8dB
传热系数 Thermal conductivity	1.13m ² °C/W
最大长度 Max length	3000mm
板重 Panel weight	15.9kg/m ²

天花板系统

Ceiling System

一、适用范围 Scope of Use

各类船舶及海洋工程建筑物上具有耐火分隔要求的舱室和生活模块。

The cabins & living modules with fireproof division requirement of structures on various ships and sea projects.

二、天花板图例 Figures of Ceiling System

雌雄天花板 Ceiling (T25A)

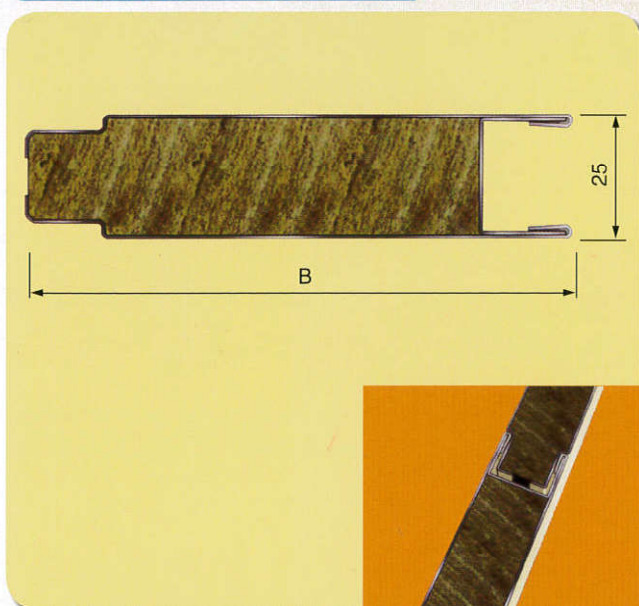

面材 Surface material	0.6mm贴塑钢板 0.6mm PVC laminated steel sheet
芯材 Core material	150kg/m ³ 岩棉 150kg/m ³ Rockwool
防火等级 Fire class	B-0 / B-15
隔音量 Sound reduction	42dB
传热系数 Thermal conductivity	0.50m ² °C/W
最大长度 Max length	3000mm
板重 Panel weight	13.9kg/m ²

雌雄天花板 Ceiling (T50A)

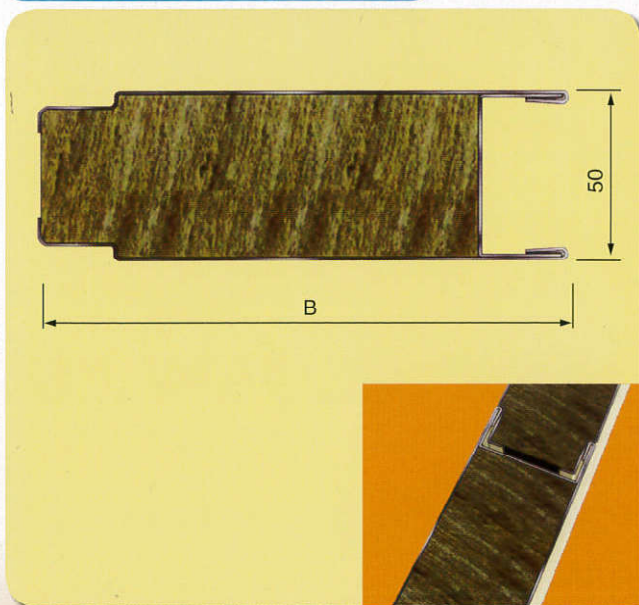

面材 Surface material	0.6mm贴塑钢板 0.6mm PVC laminated steel sheet
芯材 Core material	150kg/m ³ 岩棉 150kg/m ³ Rockwool
防火等级 Fire class	B-0 / B-15
隔音量 Sound reduction	42dB
传热系数 Thermal conductivity	1.04m ² °C/W
最大长度 Max length	3000mm
板重 Panel weight	15.2kg/m ²



天花板系统

Ceiling System

端头天花板 Ending Ceiling (T25A)

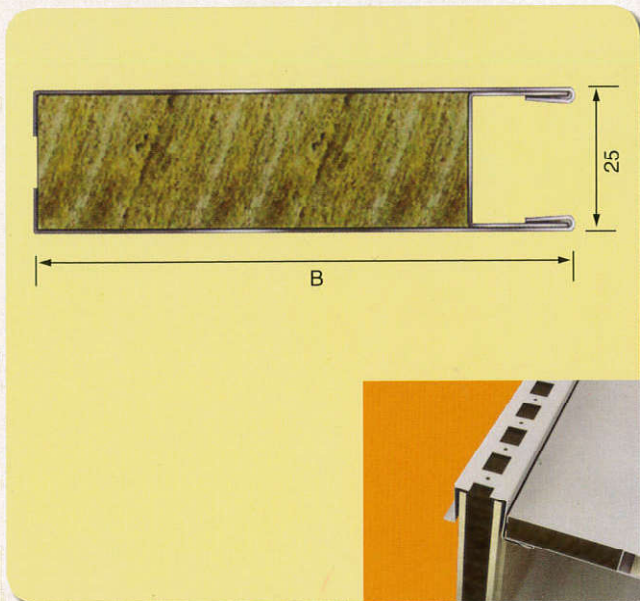

面材 Surface material	0.6mm贴塑钢板 0.6mm PVC laminated steel sheet
芯材 Core material	150kg/m ³ 岩棉 150kg/m ³ Rockwool
防火等级 Fire class	B-0 / B-15
隔音量 Sound reduction	42dB
传热系数 Thermal conductivity	0.50m ² °C/W
最大长度 Max length	3000mm
板重 Panel weight	12.9kg/m ²

端头天花板 Ending Ceiling (T50A)

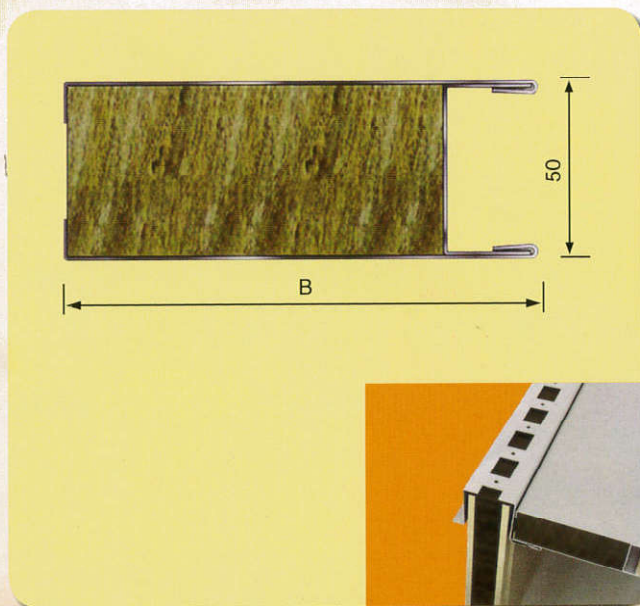

面材 Surface material	0.6mm贴塑钢板 0.6mm PVC laminated steel sheet
芯材 Core material	150kg/m ³ 岩棉 150kg/m ³ Rockwool
防火等级 Fire class	B-0 / B-15
隔音量 Sound reduction	42dB
传热系数 Thermal conductivity	1.04m ² °C/W
最大长度 Max length	3000mm
板重 Panel weight	15.2kg/m ²

舱室样例

Example Of Cabin

舱室安装节点 Detail of installation

衬板 安装节点
Detail of lining installation

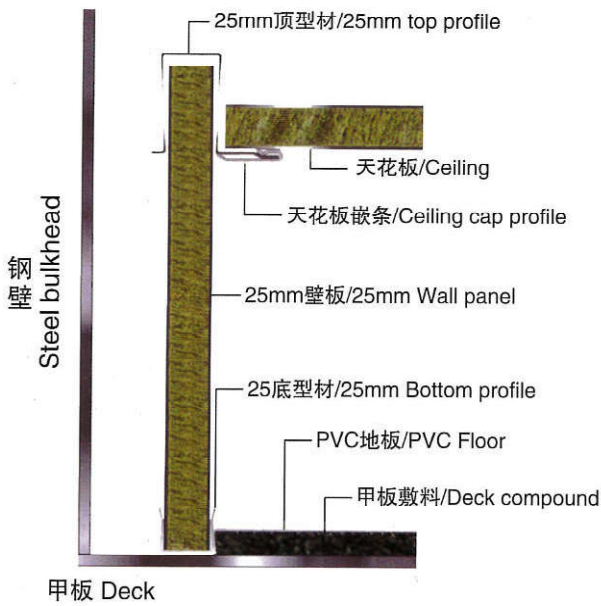

衬板在潮湿房间安装节点
Detail of lining installation in wet cabin

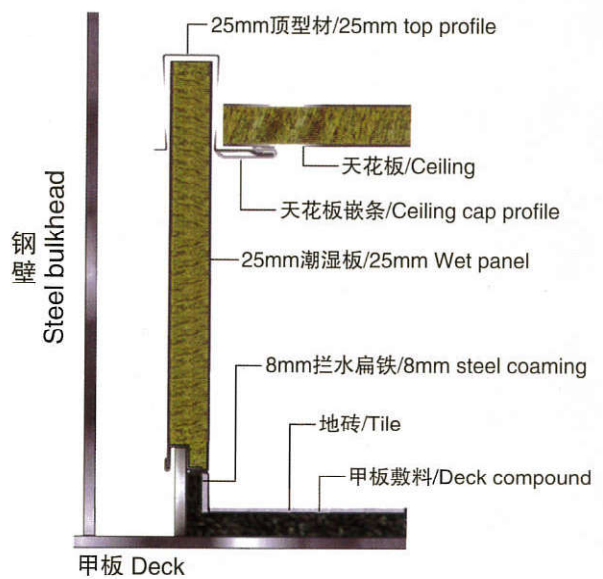

独立围壁安装节点
Detail of partition installation

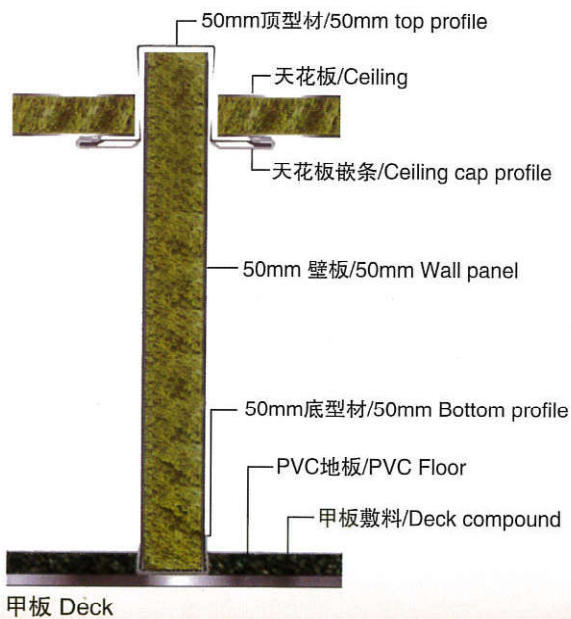

独立围壁在潮湿间安装节点
Detail of partition installation in wet cabin

